

Clinical evolution of women with XLAS

Κ. ΔΕΡΜΙΤΖΑΚΗ¹, Δ. ΛΥΓΕΡΟΥ¹, Π. ΙΩΑΝΝΟΥ², Π. ΣΥΓΓΕΛΑΚΗ¹, Σ. ΣΤΡΑΤΑΚΗΣ¹, Σ. ΣΤΡΑΤΗΓΗΣ¹, Κ. ΠΕΡΑΚΗΣ¹, Ε. ΝΤΑΟΥΝΤΑΚΗ³, Γ. ΠΕΡΥΣΙΝΑΚΗ³, Γ. ΤΖΑΝΑΚΗΣ⁴, Ε. ΔΑΦΝΗΣ¹, Κ. ΔΕΛΤΑΣ⁵, Κ. ΣΤΥΛΙΑΝΟΥ¹.

¹ΝΕΦΡΟΛΟΓΙΚΗ ΚΛΙΝΙΚΗ ΠΑΓΝΗ, ²ΠΑΘΟΛΟΓΙΚΗ ΚΛΙΝΙΚΗ ΠΑΓΝΗ, ³ΝΕΦΡΟΛΟΓΙΚΗ ΚΛΙΝΙΚΗ Γ.Ν. ΡΕΘΥΜΝΟΥ, ⁴ΝΕΦΡΟΛΟΓΙΚΗ ΚΛΙΝΙΚΗ Γ.Ν. ΧΑΝΙΩΝ, ⁵ΤΜΗΜΑ ΒΙΟΛΟΓΙΚΩΝ ΕΠΙΣΤΗΜΩΝ, ΠΑΝΕΠΙΣΤΗΜΙΟ ΚΥΤΤΡΟΥ.

Natural history of disease...

- 1927, Alport A. :
“male members of a family tend to develop nephritis and deafness and do not as a rule survive...the females have deafness and hematuria and live to old age.”
- 1964, Percoff GT. :
“females usually remain well throughout life...and only rarely have women died of the disease”
- 2003, Gubler et al. :
substantial burden of kidney disease in female population

Alport syndrome...

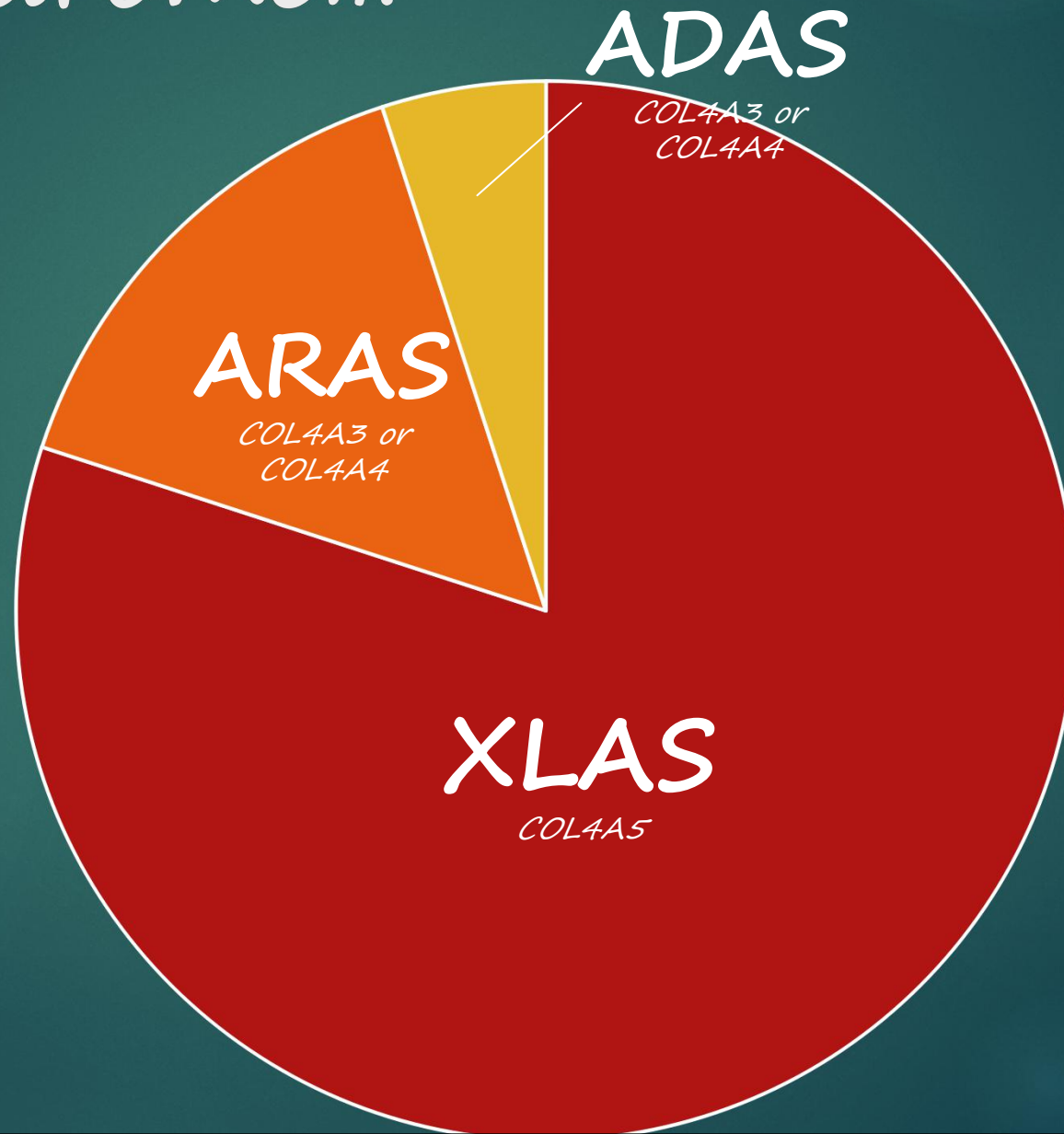

Potential pathogenesis mechanism of AS

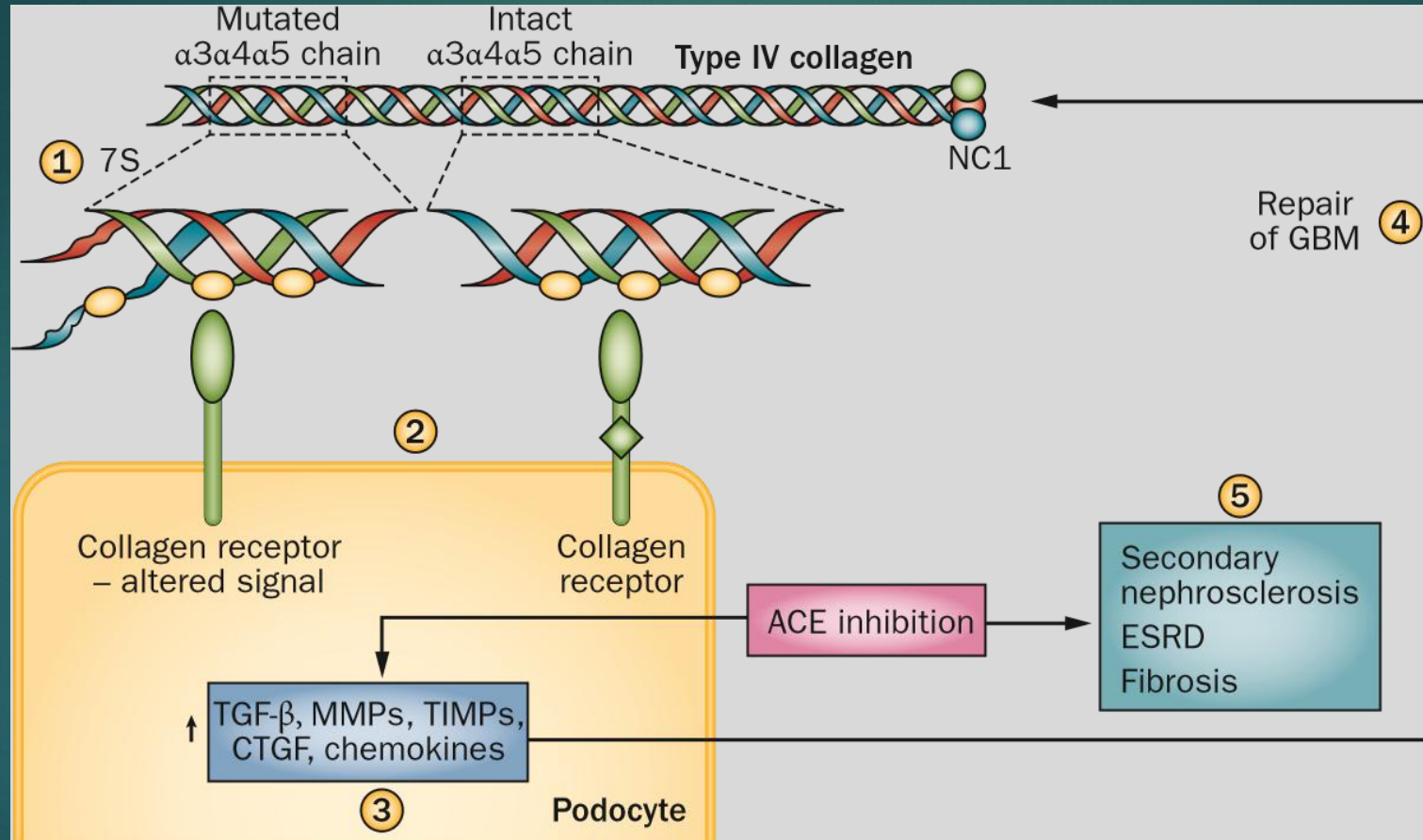

Figure 1 | Potential mechanisms underlying chronic renal disease occurring in Alport syndrome

Summary of clinical and pathologic findings in the 195 Alport syndrome families with proven COL4A5 mutation



Variable	Families with Proven COL4A5 Mutation
^a ESRD, end-stage renal disease; GBM, glomerular basement membrane; GN, glomerulonephritis.	
Consanguinity	5 of 192 (2.5%)
Familial history	171 of 193 (88.5%)
Hematuria	191 of 193 (99%)
ESRD	146 of 193 (76%)
Hearing loss	156 of 189 (82.5%)
Ocular changes	66 of 149 (44%)
Leiomyomatosis	9 of 176 (5%)
Ultrastructural GBM changes	115 of 117 (98%)
Immunohistochemical GBM changes	23 of 27 (85%)
Transplantation	106 of 195 (54%)
Posttransplantation anti-GBM GN	3 of 80 (4%)

Probability of end-stage renal disease (ESRD) in 315 boys and men and 288 girls and women with COL4A5 mutation.

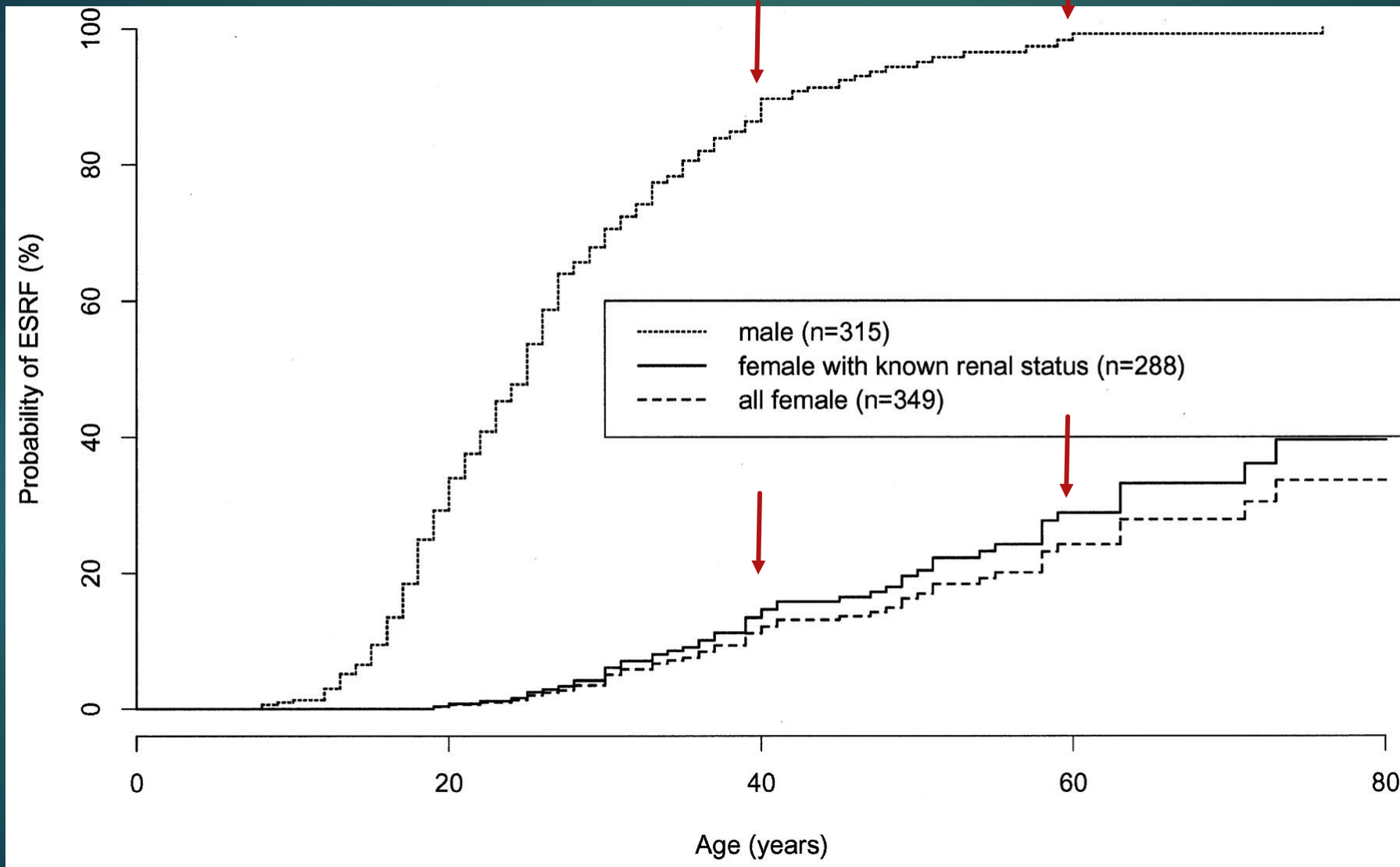

Probability of hearing loss in 144 boys and men and 151 girls and women with COL4A5 mutation.

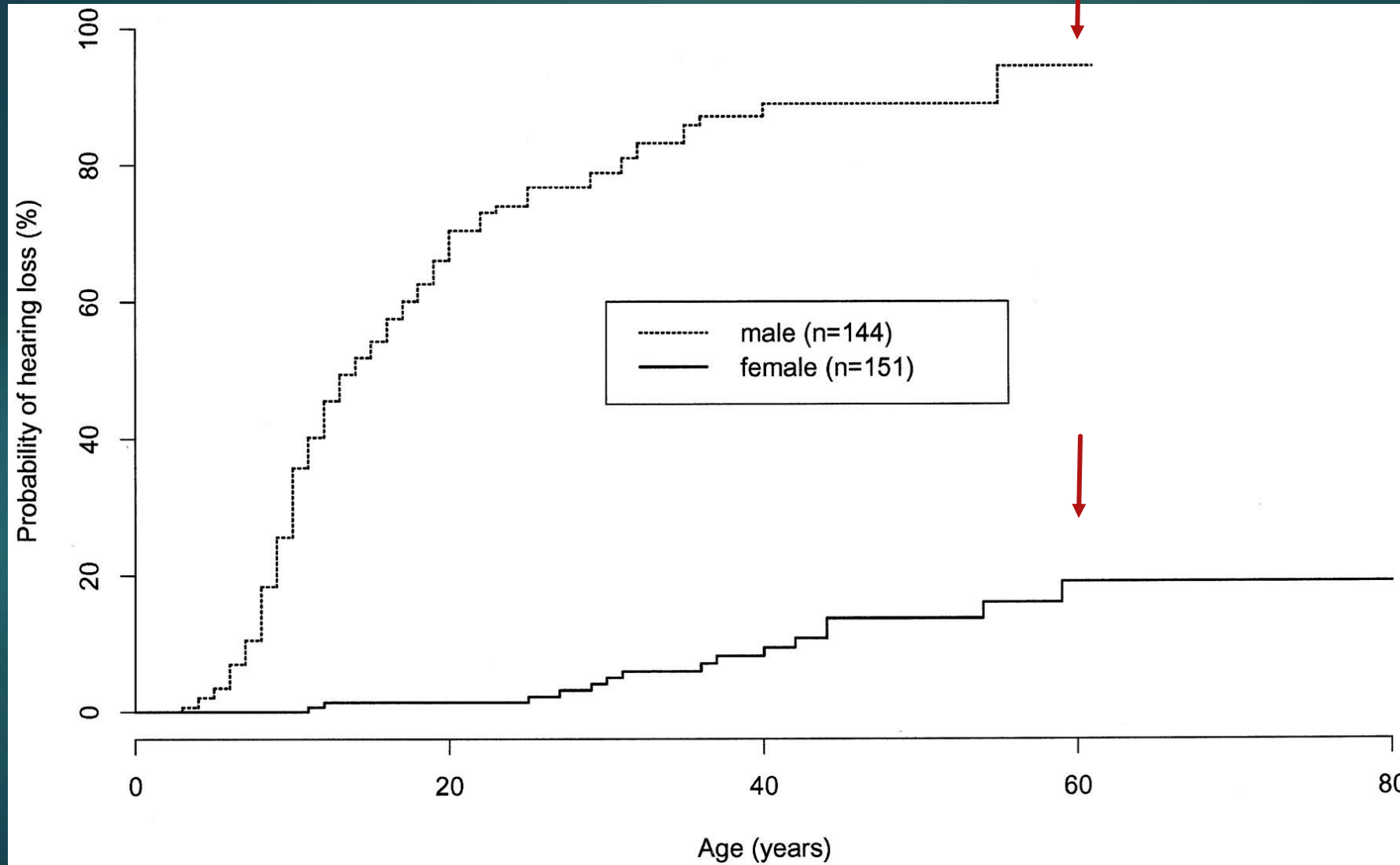

Clinical evolution of women with XLAS

- 7 families with different mutations
- 48 family members (18 males/30 females), 30 of them with a X-linked transmission (8 men/22 women)
- 7/22 performed kidney biopsy before genome analysis
- follow-up for 5 years

Results...

- Age between 7 and 78 yo (mean age 32 yo)

- 7 biopsies performed
 - 2 Alport syndrome
 - 2 FSGS
 - 1 TBMD
 - 1 post-infectious GN
 - 1 IgM nephropathy

Results...

- 54%, (7-46 yo) presents hematuria, but no CKD
- 18% CKD (renal impairment or proteinuria >1gr, 7-60 yo)
- 27% ESRD (20-70 yo)

Family	Carrier s ♀	Mutation		Hematuria (Age)	CKD (Age)	ESRD (Age*)
5459	4	c.2228G>T	p.G743V	2 (18, 18)	1 (52)	1 (70)
5315	3	c.3106G>A	p.G1036R	1 (38)	1 (60)	1 (21)
1000	2	c.4688+5G>A		0	1 (7)	1 (21)
5359	4	c.1094G>T	p.G365V	4 (28, 30, 32, 33)	0	0
4208	1	2946delT*fs	Stop995	1 (46)	0	0
4210	3	c.682G>T	p.E228X	1 (7)	1 (55)	1 (70)
5360	5		p.P907S	3 (27, 28, 28)	0	2 (34, 50)
Total	22			12 (54%)	4 (18%)	6 (27%)

Mutation in c.4688+5G>A in COL4A5 gene

- not described yet
- located in a region of the gene where the changes are pathogenic
- not found in normal individuals / found only in the affected members of the family
- refers to a highly conserved nucleotide at the intron-exon limit, which may affect the splicing process
- C.4688+4G described before

Family 1000

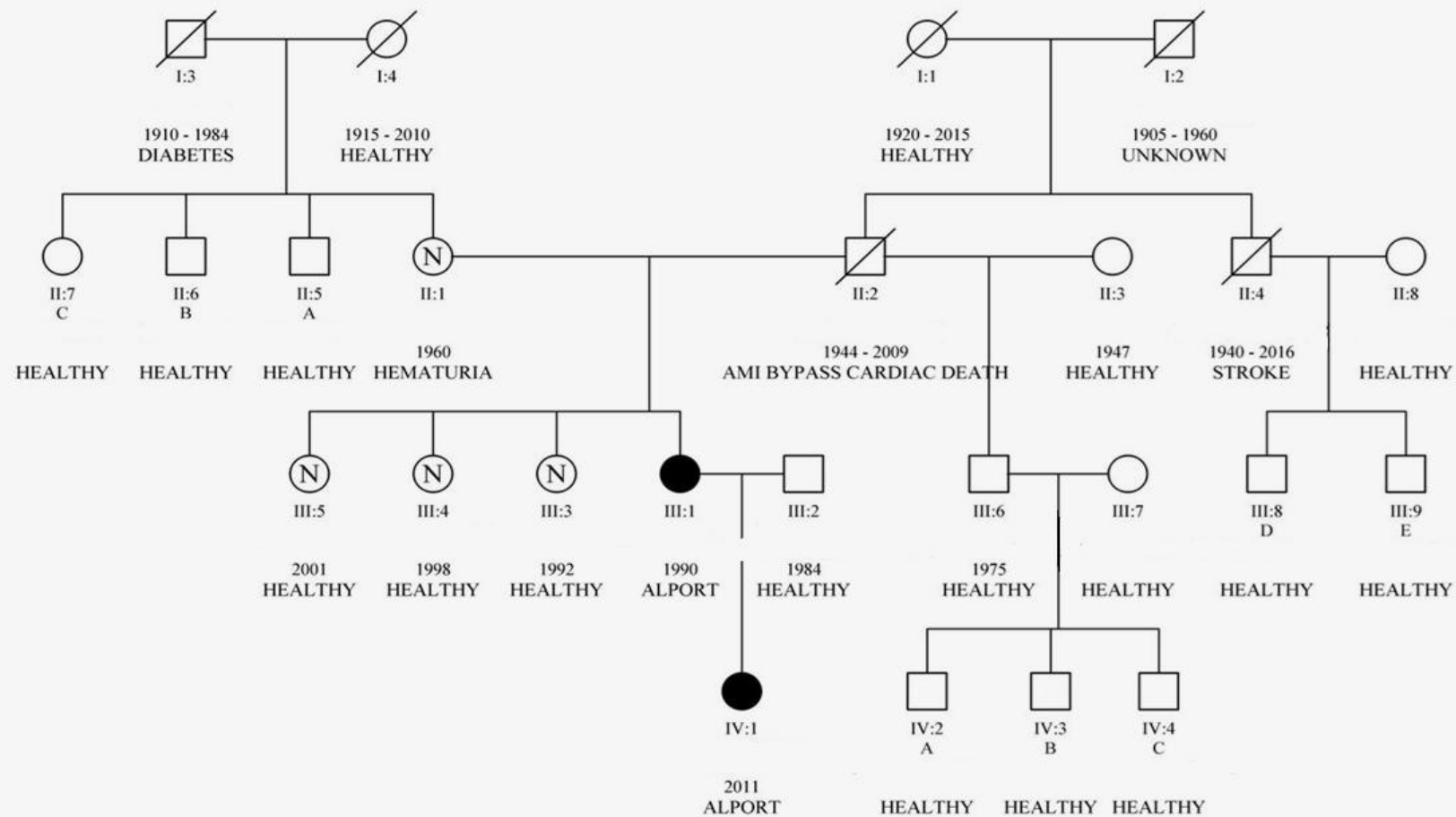

Family 5315

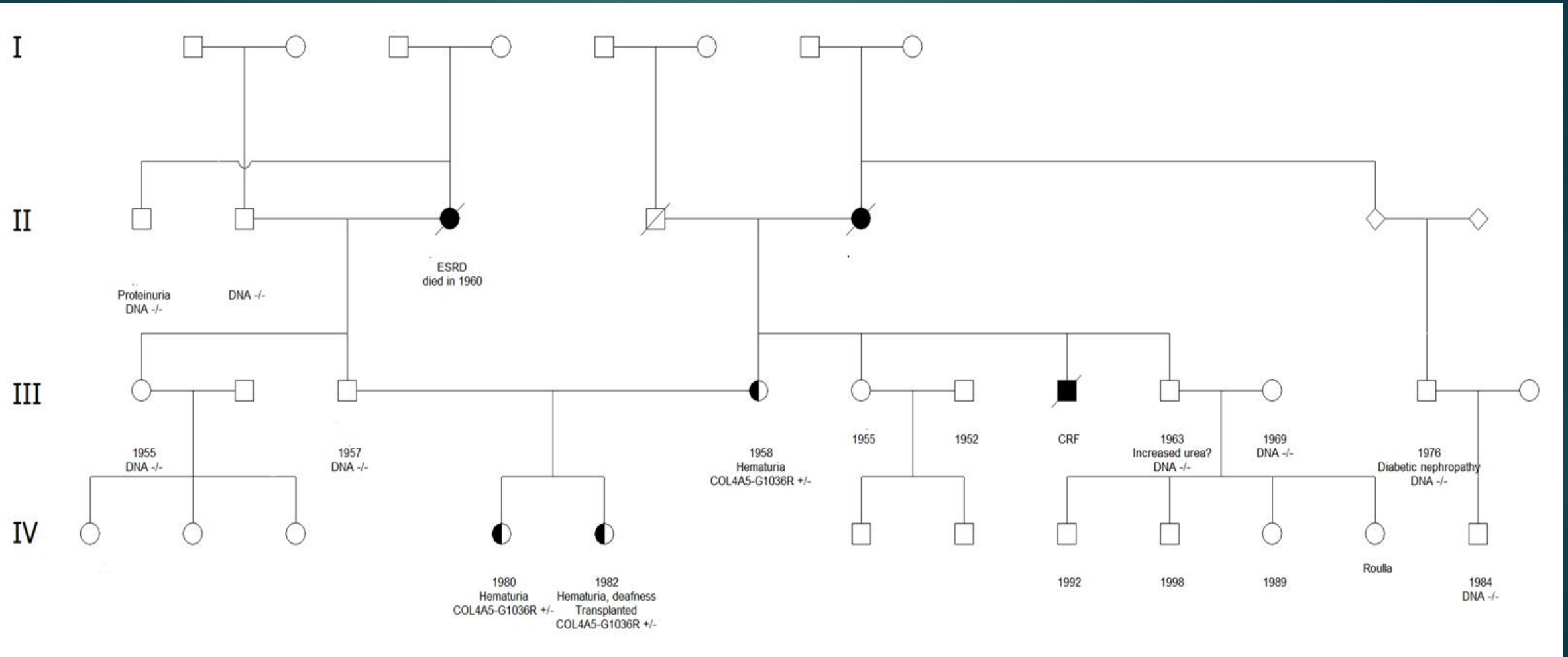

Conclusions...

- Renal biopsy in pt with XLAS is often non-diagnostic
- XLAS IS NOT a benign disease for heterozygous women:
 - 27% of them ESRD
 - Almost half of the affected women reach ESRD in young age (same with men)

Possible explanation: asymmetric inactivation of the X chromosome or the existence of modifying genes can affect phenotype